



DC High Voltage Contactor
直流高压接触器 **WM680**

L×W×H(mm): 30×55.8/44/56×30.6mm
30×29.2×30.1mm



A Type



B Type



L Type

- 1 Form A contact arrangement;
- Carrying current 20A continuously at 85°C;
- Available shell types available;
- Typical applications: new energy automobile.

Ordering Information 订货说明

WM680	- 12	A	- B	- P	- S	20	XXX
1	2	3	4	5	6	7	8

1 Part number 型号: WM680
 2 Coil rated Voltage(VDC)线圈额定电压: 12: 12V; 24: 24V
 3 Contact Form 触点形式: A: 1 Form A;
 4 Shell Structure 外壳安装类型: A: A type mounting flange (A 型安装外壳); B: B type mounting flange (B 型安装外壳);
 L: L type mounting flange (L 型安装外壳); Nil: Without mounting flange 外壳不带安装法兰
 5 Terminals 引出脚方式: P: PCB type 为 PCB 焊接式; Nil: QC type 快接式
 6 Enclosure 封装方式: S: Sealed 密封式
 7 Contact load 触点负载: 20: 20A/450VDC
 8 xxx: Customer special code 客户特殊要求

Contact Data 触点参数

Contact Form 触点形式	1A (1 Form A)
Contact Material 触点材料	Silver alloy
Contact Rating (resistive)触点负载 (阻性)	20A/450VDC
Max. Breaking Current 最大断开电流	30A @ 450VDC (5ops)
Max. Switching Voltage 最大切换电压	750VDC
Max. Switching Power 最大切换功率	18000W
Contact Resistance or Voltage drop 接触电阻或接触压降	≤5mΩ (@ 20A)
Mechanical Life 机械寿命	2×10 ⁵ cycles
Electrical Life 电气寿命 (at 23 °C) 常温 0.6s on 5.4s off 0.6 秒通 5.4 秒断	3000 cycles (20A/450VDC)

Coil Parameter 线圈参数

Dash numbers 规格	Coil voltage 线圈电压(VDC)		Coil resistance 线圈电阻 Ω±10%	Pickup voltage VDC (Max.) 最大起动电压	Release voltage VDC (Min.) 最小释放电压	Coil power 线圈功率	Operate Time 起动时间	Release Time 释放时间
	Rated 额定	Max. 最大						
12V	12	15.6	48	9	1	3W	<30 ms	<10 ms
24V	24	31.2	192	18	2			



Operation condition 工作条件

Insulation Resistance 绝缘电阻		1000MΩ Min. (at 500VDC)
Dielectric Strength 介质耐压	Between Contacts	2500VAC / 1 min. (test current: 10mA)
	Between Coil and Contacts	3000VAC / 1 min. (test current: 10mA)
Ambient Temperature 环境温度		-40°C ~ +85°C
Shock resistance 抗冲击	Functional 稳定性	196m/s ² {20G}
	Destructive 强度	490m/s ² {50G}
Vibration resistance 抗震		10 ~ 500Hz, 49m/s ² {5G}
Relative Humidity 相对湿度		5% ~ 85%RH
Terminal type 脚位类型		PCB type 为 PCB 焊接式; QC type 快接式
Weight 重量(Approx.)		48g(A type), 50g(L type)

Layout (Unit: mm)外形尺寸、接线图

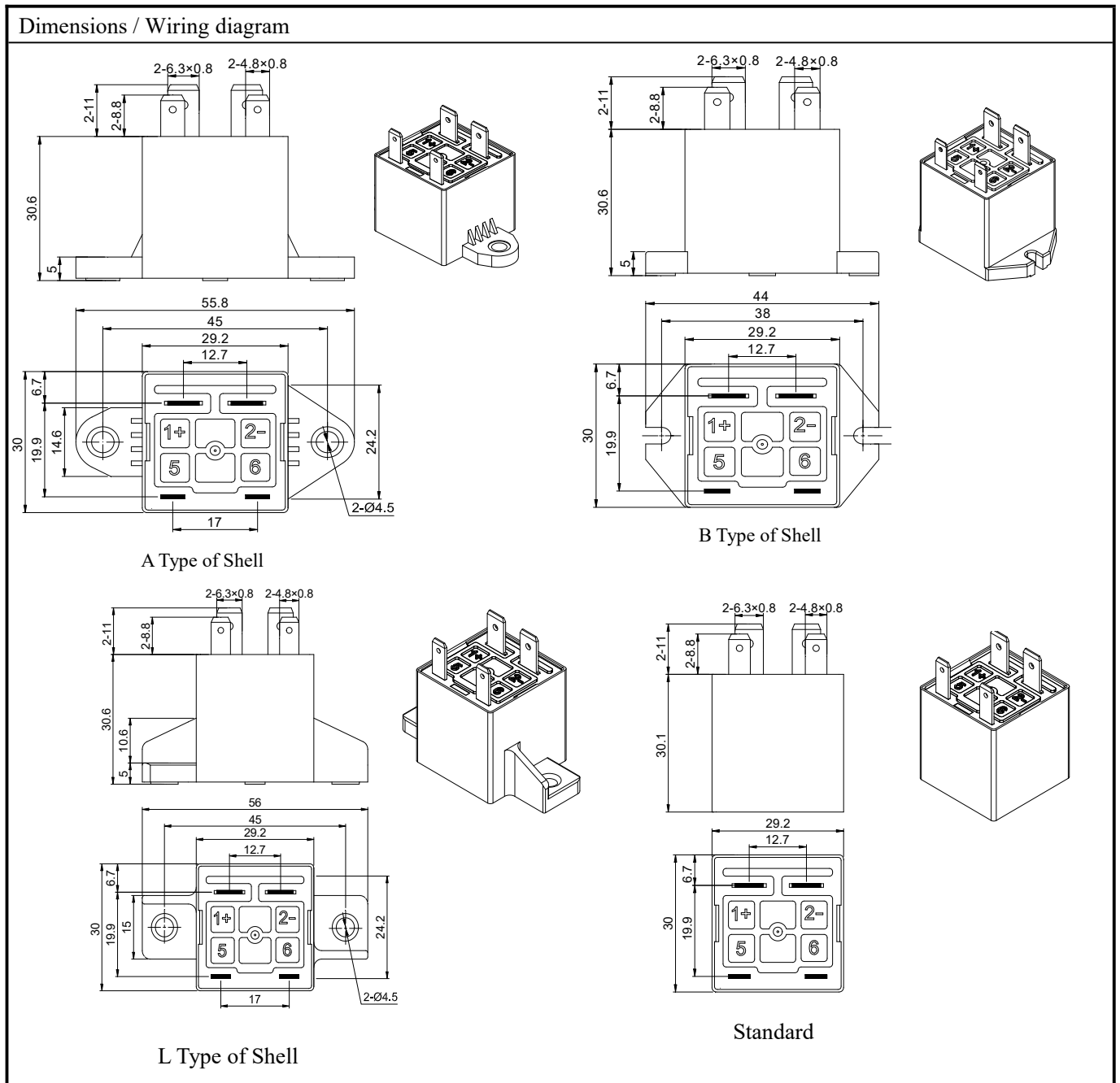

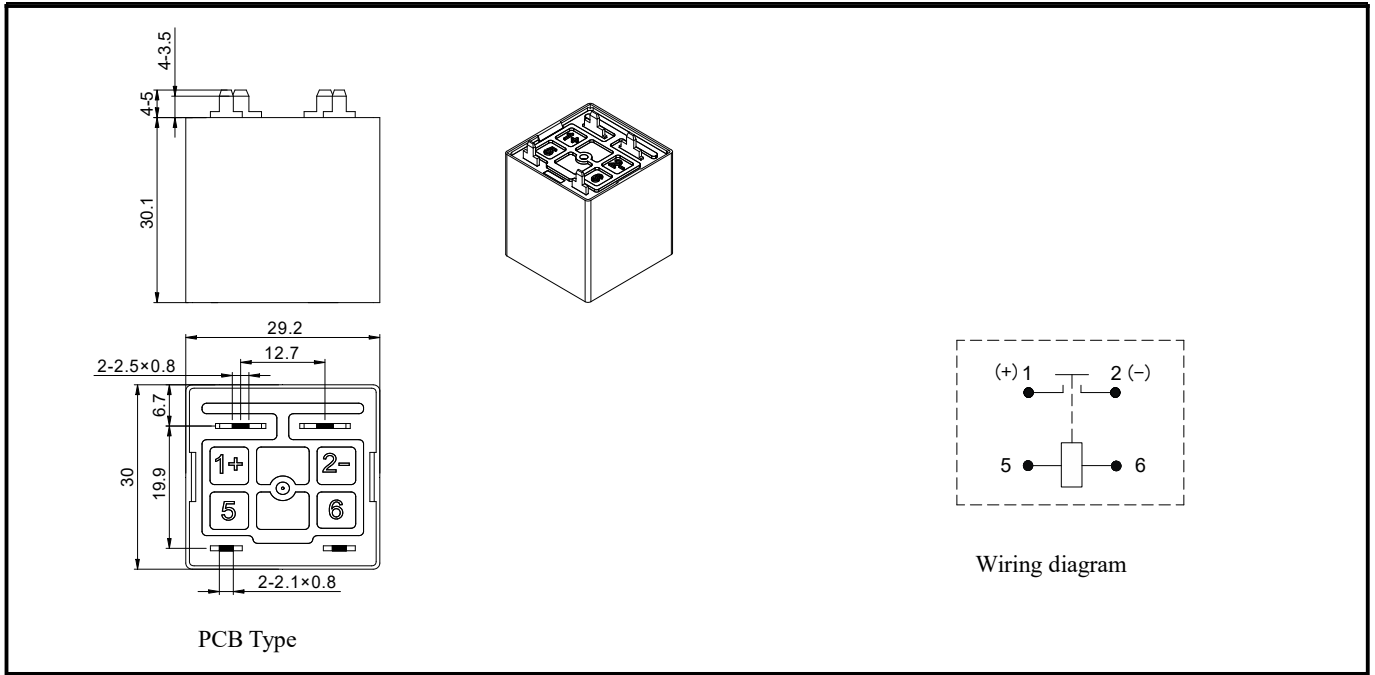

Characteristic Curves 特性曲线

Endurance Capacity Curve

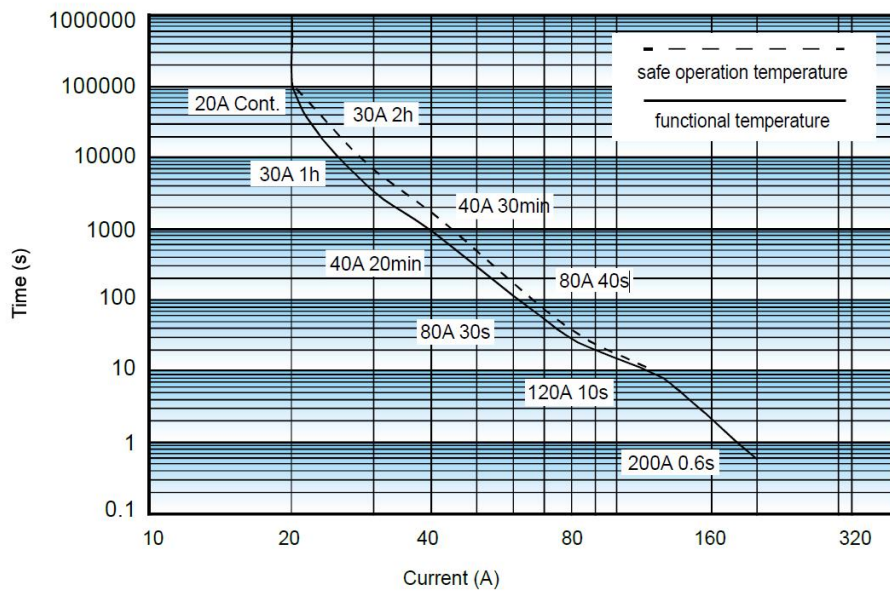

Pick-up Voltage / Drop-out Voltage Curve

